

VISUAL PHYSICS ONLINE

MODULE 4.1

ELECTRICITY

DC CIRCUITS 1



Charge q Q Δq ΔQ [C coulomb]

Current I i [A ampere]

time interval Δt [s second]

$$I = \frac{\Delta q}{\Delta t}$$

potential / potential difference / voltage / emf

V ΔV ε emf [V volt]

resistance R [Ω ohm]

$$R = \frac{\Delta V}{\Delta I}$$

energy E E_e W [J joule]

$$W = P \Delta t$$

power P [W watt]

$$P = \frac{\Delta W}{\Delta t} = V I = I^2 R = V^2 / R$$

Ohm's Law

(constant resistance and constant temperature)

$$V = I R \quad I = \frac{V}{R}$$

Kirchhoff's Junction Rule

at any junction $\sum I = 0$

Kirchhoff's Loop Rule

around any loop $\sum V = 0$

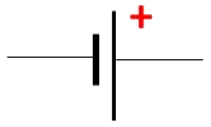
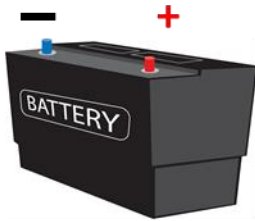

battery emf
 \mathcal{E}

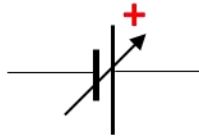

variable emf



switch

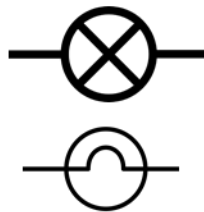

light globe



resistors

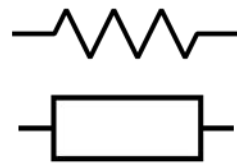

ammeter

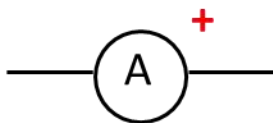

voltmeter

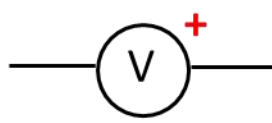

multimeter V A Ω

Circuit Symbols

REVIEW: Electric Currents

emf ε [V]

The source of electrical energy required to produce an electric current in a circuit is known as the **emf** ε (electromotive force).

For example, in a torch, the source of electrical energy is a battery. Chemical reactions take place within the battery to maintain an imbalance of charge between the positive and negative terminals. This charge imbalance gives rise to the battery's emf which is simply the potential difference between the two terminals.

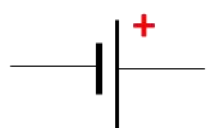
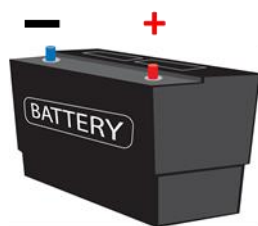

battery emf
 $\varepsilon = 12 \text{ V}$

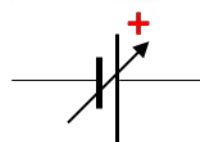

variable emf
 $\varepsilon = (0 \text{ to } 30) \text{ V}$

Resistance R [Ω]

An **electrical resistance** R is a property of any component in a circuit in which electrical energy is dissipated and appears as thermal or light energy. For example, when current passes through an incandescent light globe, collisions between the free electrons and the positive ion lattice, increases the thermal energy of the globe, resulting in an increase in the temperature of the globe's filament and the emission of light.

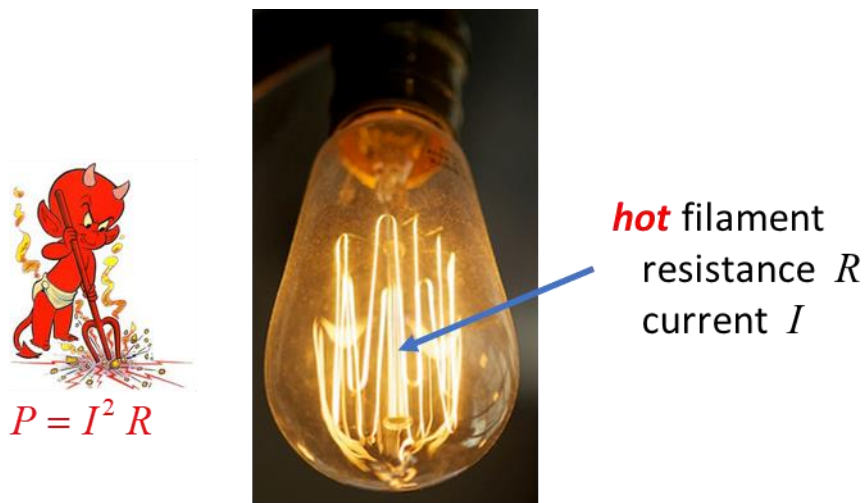

electrical energy \longrightarrow **thermal** / **light** energy
 $P = I^2 R$

When a dissipative component which has resistance R has a potential difference ΔV across it, the current I that passes

through it is $I = \frac{\Delta V}{R}$.

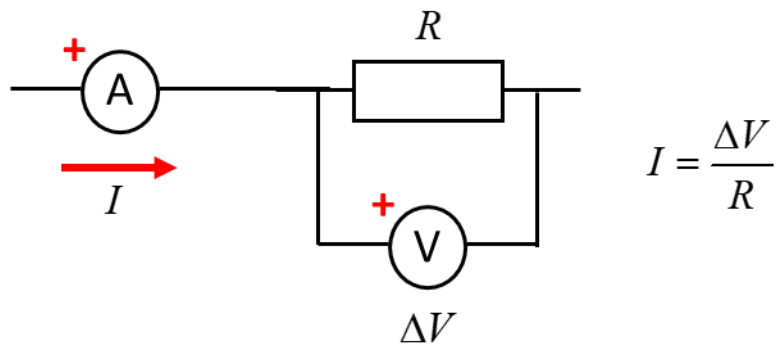

The **resistance** R for any given current through it is defined by the ratio

$$R = \frac{\Delta V}{\Delta I}$$

where ΔI is the change in current through the resistance for the change in the potential difference ΔV across the resistor. The S.I. unit for resistance is the ohm Ω .

The **resistance** for a component is usually **not constant** as the current through it is changes. For example, as the current through a light globe increases, it gets hotter and hotter and its resistance continually increases. The value of the resistance depends upon the value for the current.

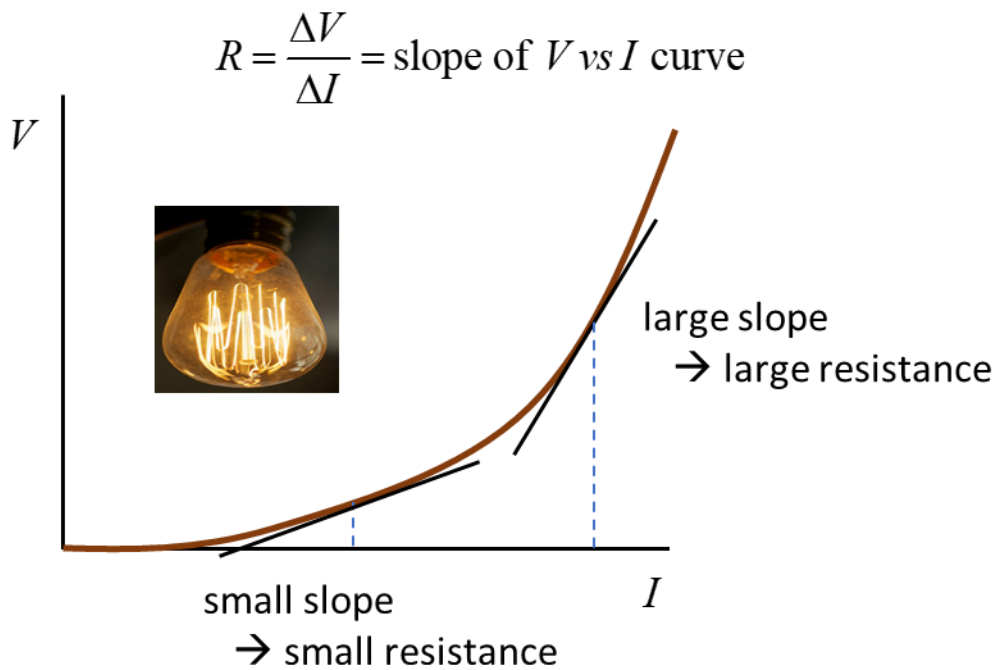

Fig. 1. The V vs I graph for an incandescent light globe. As the current through the light globe increases, it gets hotter and hotter and its resistance continually increases.

The equation $I = \frac{V}{R}$

implies that the current which flows in response to a potential difference depends upon the resistance value.

- The greater the potential difference across the resistance the greater the current.
- The smaller the resistance value, the greater the current through the resistance.

Many materials, such as metals, it is found that that ratio $\Delta V / \Delta I$ is constant over a wide range of potential difference and current values. That is, the resistance R is independent of the current or potential difference. This relationship was found by Georg Ohm (1787 – 1854) and is known as **Ohm's Law**.

$R = \text{slope of } V \text{ vs } I \text{ curve}$

$$R = \frac{\Delta V}{\Delta I} = \text{constant}$$

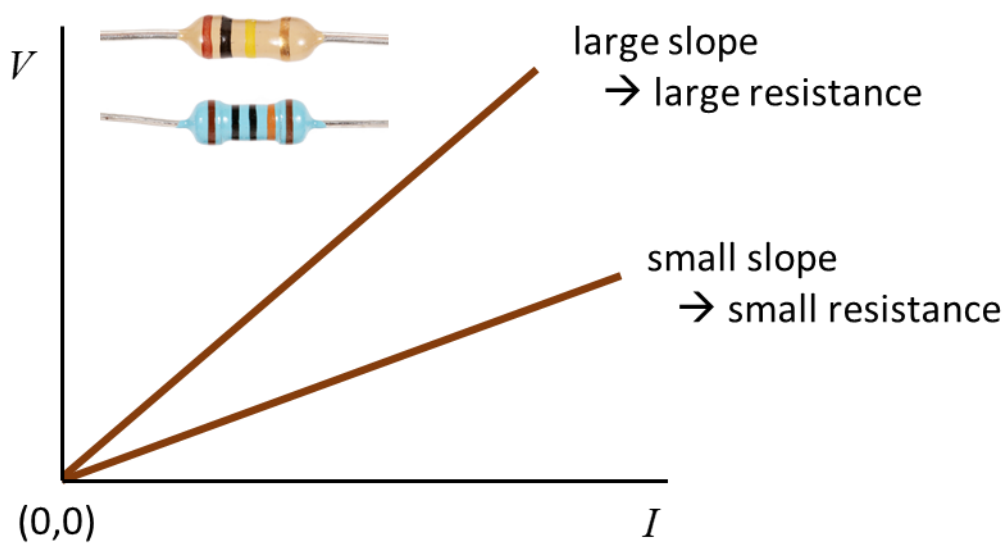

Equation of straight line through origin

$$V \propto I \quad V = RI$$

R is the constant of proportionality and corresponds to the slope of the V vs I straight line

$$V = IR \quad R = \frac{V}{I} = \text{constant} \quad \text{Ohm's Law}$$

This Law holds provided the temperature of the material remains constant. Components which obey Ohm's Law are often referred to as **ohmic** or **linear** devices. For ohmic components, the current through it is proportional to the potential difference across its ends provided the temperature remains constant

$$I \propto V \quad I = \frac{V}{R} \quad \text{Ohm's Law}$$

Kirchhoff's Loop Rule or Kirchhoff's Voltage Law

The algebraic sum of all the potential differences around any closed loop of a circuit is zero.

$$\sum_{loop} V = 0$$

Consider the circuit shown in figure 2.

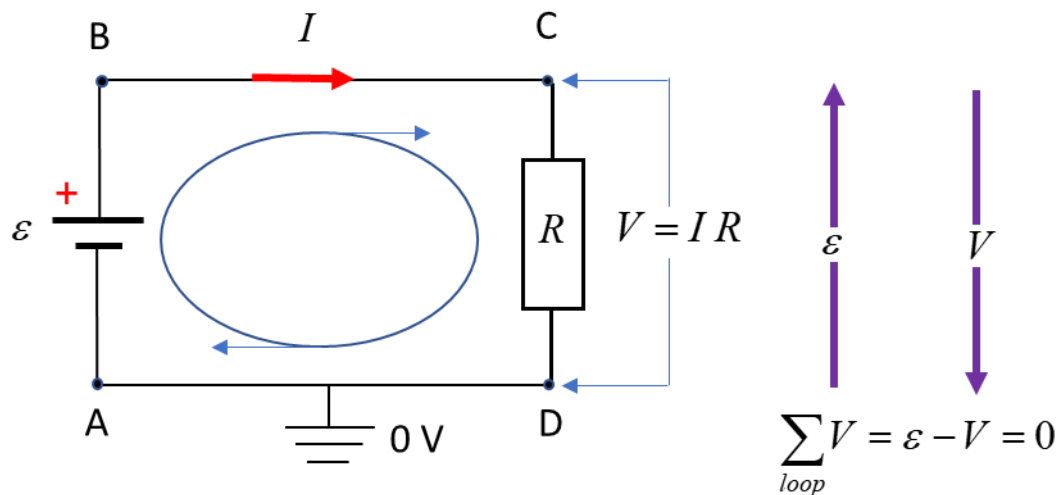

Fig. 2. Kirchhoff's loop rule states that as one moves around a closed loop in a circuit, the algebraic sum of all potential differences must be zero. The electric potential increases as one moves from the $-$ to the $+$ plate of a battery; it decreases as one moves through a resistor in the direction of the current.

Any points connected by an ideal conductor will have the same potential. Points A and D are connected by an ideal conductor, so we can set

$$V_A = V_D = 0$$

Consider the changes in potential in going around the loop ABCD in a clockwise sense and the direction of the current also be in a clockwise direction. The electric potential increases by an amount ε in going from point A to point B since we move from a low potential point (negative terminal of battery) to a high potential point (positive terminal of battery). In going from point

B to C, the two points are at the same potential since they are connected by an ideal conductor

$$V_B = V_C = \mathcal{E}$$

In moving from point C to D, the potential must drop to zero, therefore we must have

$$\begin{aligned}\mathcal{E} - V &= \mathcal{E} - IR = 0 \\ \mathcal{E} &= V \quad \mathcal{E} = IR\end{aligned}$$

The Kirchhoff's Loop rule is a statement of conservation of energy. The energy supplied by the battery is dissipated in the resistor.

An alternative expression which is often easy to use for numerical problems is

$$\sum_{loop} \mathcal{E} = \sum_{loop} V \quad \text{sum emf} = \text{sum voltage drops}$$

Kirchhoff's Junction Rule or Kirchhoff's Current Law

The algebraic sum of all currents meeting at a junction a circuit must be zero.

$$\sum_{\text{junction}} I = 0$$

Currents entering a junction are positive quantities and currents exiting a junction are negative quantities as shown in figure 3.

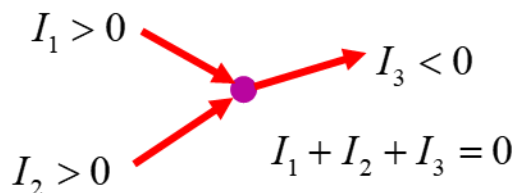
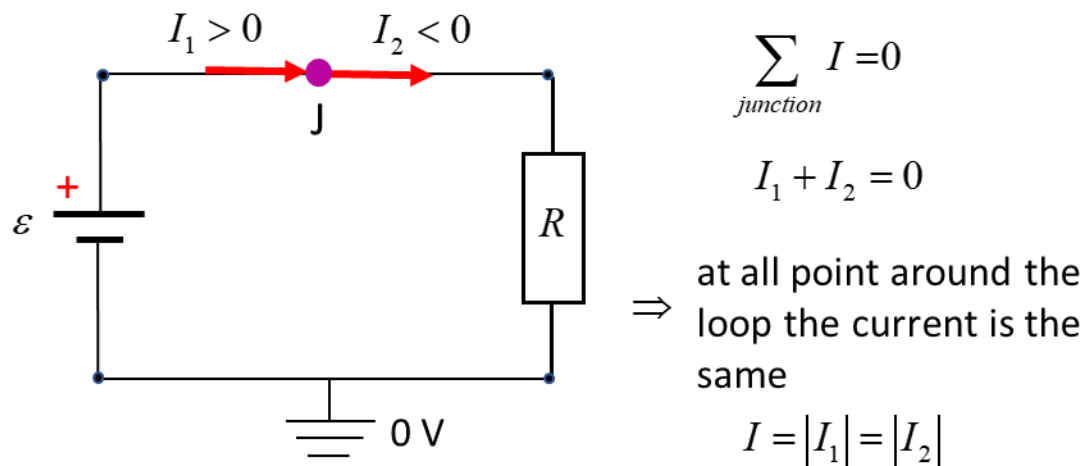

Fig. 3. Kirchhoff's junction rule: The algebraic sum of all currents meeting at a junction a circuit must be zero.

The junction rule follows from observations that the current entering any point in a circuit must equal the current leaving that point. If this were not the case, charge would either build up or vanish from a circuit. The junction rule is simply a way of expressing the law of conservation of charge.

Note: In solving circuit problems and applying Kirchhoff's laws, be sure to use the appropriate sign for loops, currents and potential differences. The direction of the current and loop are arbitrary. If you get a negative answer for a current, it means the direction is opposite to the assigned direction.

Kirchhoff's Junction and Loop Rules are fundamental relationships for solving DC circuit problems. Select a loop for analysis and any point as a starting point to move around the loop in either a clockwise or anticlockwise direction. Choose the current to be in the same direction in which the loop is to be followed around. Determine the potential difference across each component of the circuit, however, you need to be very careful in assigning the sign to each potential difference.

Sign of the potential difference V (voltage drop) across a resistor

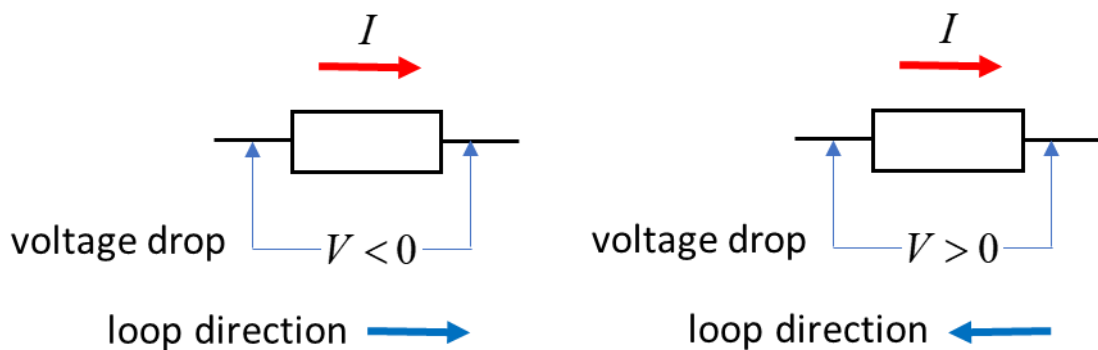

Sign of the potential difference V (emf) across a battery

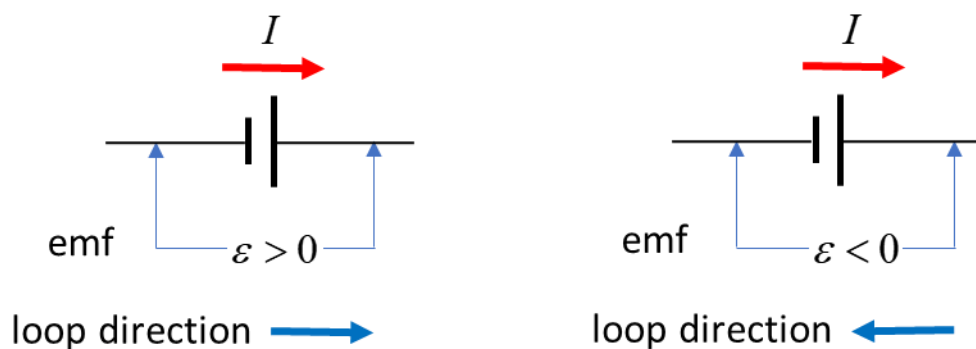

If the result of your calculations gives a negative value for the current, it means that the current direction is opposite to the one chosen.

Energy Conservation

The thermal energy produced by a current through a resistance is a result of the collisions that occur between the conduction electrons and the atom of the material.

When a charge Δq is transferred between two points with a potential difference ΔV , then work ΔW is done by the charge or on the charge, which results in a change in potential energy ΔU of the charge, such that

$$|\Delta W| = |\Delta U| = |q \Delta V|$$

The time rate of energy transfer, the power P is

$$P = \frac{|\Delta W|}{\Delta t} = \frac{|\Delta U|}{\Delta t} = \frac{|q \Delta V|}{\Delta t} \quad I = \frac{\Delta q}{\Delta t}$$
$$P = I \Delta V$$

The potential difference ΔV is often just expressed as V , so

$$P = V I$$

The rate of energy dissipation in a resistor R is

$$P = V I = V^2 / R = I^2 R \quad V = I R \quad I = V / R$$

Example 1

Two batteries are connected in opposition as shown in the figure. Battery 1 has an emf of 18.0 V and battery 2 has an emf of 6.00 V. The two batteries are connected to two resistors in series with resistances of 2.00 Ω and 1.00 Ω .

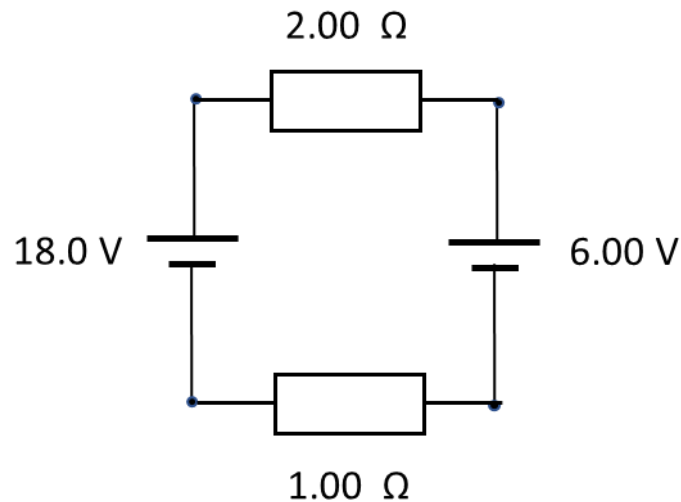

Calculate the following:

1. Current from each battery.
2. Current through each resistor.
3. Potential difference across each resistor.
4. What is the rate of energy supplied by each battery?
5. What is the rate of energy dissipated by each resistor?
6. Show that energy is conserved in the circuit.

Solution

Draw the circuit diagram, labelling each component, the loop direction and current direction.

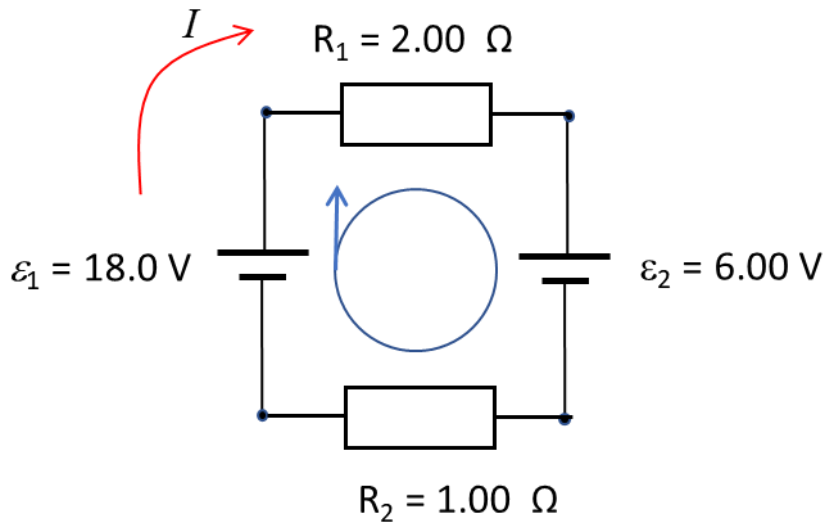

emfs $\varepsilon_1 = 18.0 \text{ V}$ $\varepsilon_2 = 6.00 \text{ V}$

resistances $R_1 = 2.00 \text{ } \Omega$ $R_2 = 1.00 \text{ } \Omega$

We have a single loop, and by Kirchhoff's Junction rule, the **same current passes through each device**

$$I = ? \text{ A}$$

Voltage drops $V_1 = ? \text{ V}$ $V_2 = ? \text{ V}$

Rate of energy transfer: power

batteries $P_{B1} = ? \text{ W}$ $P_{B2} = ? \text{ W}$

resistors $P_{R1} = ? \text{ W}$ $P_{R2} = ? \text{ W}$

Applying Kirchhoff's Loop (voltage) Rule

$$\varepsilon_1 - \varepsilon_2 = V_1 + V_2$$

$$V_1 = I R_1 \quad V_2 = I R_2$$

$$\varepsilon_1 - \varepsilon_2 = I(R_1 + R_2)$$

$$I = \frac{\varepsilon_1 - \varepsilon_2}{R_1 + R_2} = \left(\frac{18 - 6}{2 + 1} \right) \text{ A} = 4.00 \text{ A}$$

The potential difference across each resistance is

$$V_1 = I R_1 = (4)(2) \text{ V} = 8.00 \text{ V}$$

$$V_2 = I R_2 = (4)(1) \text{ V} = 4.00 \text{ V}$$

Check

$$\varepsilon_1 - \varepsilon_2 = (18.0 - 6.00) \text{ V} = 12.0 \text{ V}$$

$$V_1 + V_2 = (8.00 + 4.00) \text{ V} = 12.0 \text{ V}$$

$$\varepsilon_1 - \varepsilon_2 = V_1 + V_2 \quad \text{as expected}$$

Power supplied by batteries

$$P_{B1} = \varepsilon_1 I = (18)(4) \text{ W} = 72.0 \text{ W}$$

$$P_{B2} = \varepsilon_2 I = (-6)(4) \text{ W} = -24.0 \text{ W}$$

Battery 1 delivers energy at the rate of 72 W, while battery 2 is being charged at the rate of 24 W. Net rate of energy transfer by batteries is 48 W (72 W - 24 W).

Power dissipated by resistors

$$P_{R1} = V_1 I = (8)(4) \text{ W} = 32.0 \text{ W}$$

$$P_{R2} = V_2 I = 4(4) \text{ W} = 16.0 \text{ W}$$

Rate of total energy dissipated as thermal energy by resistors

$$P_R = P_{R1} + P_{R2} = (32 + 16) \text{ W} = 48.0 \text{ W}$$

But, 48.0 W was the net rate of energy transferred by the batteries to the circuit. So, the principle of energy conservation is satisfied.

[VISUAL PHYSICS ONLINE](#)

If you have any feedback, comments, suggestions or corrections please email Ian Cooper

ian.cooper@sydney.edu.au

Ian Cooper School of Physics University of Sydney

http://www.physics.usyd.edu.au/teach_res/hsp/sp/spHome.htm